

# HINTECH ELECTRIC

FEATURING...

## Emerson Climate Technologies' 50RB Series SOLENOID VALVES

Normally closed, 2-way, direct-acting. Used for liquid or discharged gas refrigerant service.

Long-life molded & screw-on coils.  
Coil voltage: 24/50-60, 120/50-60, 220-240/50-60

Extended ends solenoid valve body. Available in right angle or straight-thru. Nominal liquid capacity R22—0.54 tons. Leads length = 30"  
Maximum fluid temp: 250°F or 121°C  
Max. working pressure: 500 psig  
MOPD: 300 psig  
UL file number: MH25894

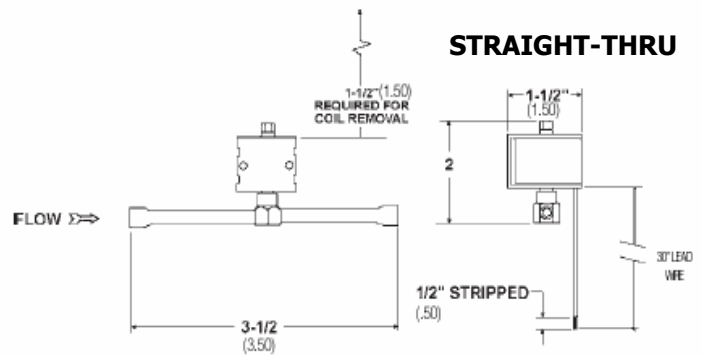
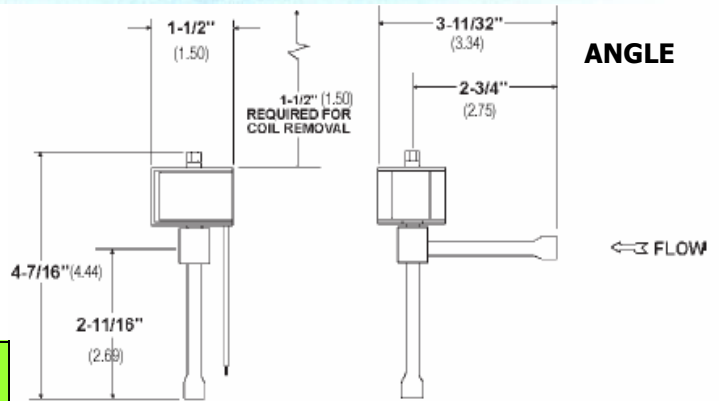

**Nominal Liquid Capacity Table For 50RB Valves (Tons)**

R-12	R-134a	R-22	R-407C	R-404A/ R-507	R-502
.34	.41	.54	.51	.34	.35

<b>Similar To</b>	<b>Series</b>
<b>Saginomiya</b>	<b>NEV / TEV</b>

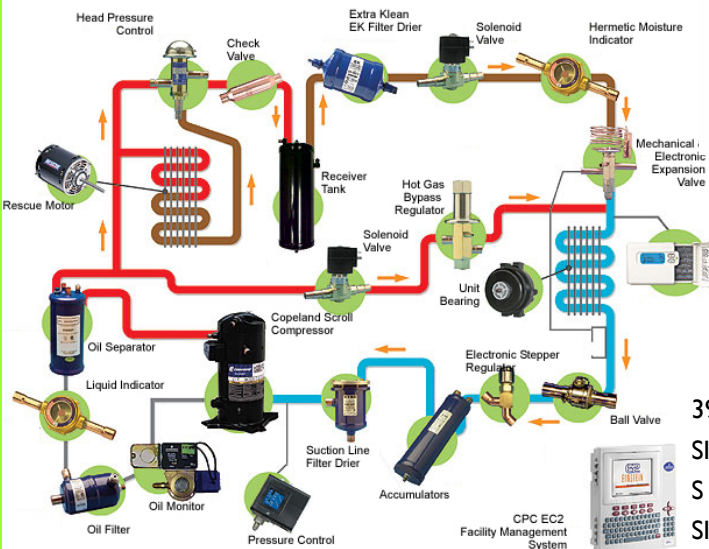

## HINTECH ELECTRIC N REFRIGERATION CONTROLS

www.hintech-electric.com      hintech.electric@gmail.com  
Authorized Full-line Distributor

392 Changi Road      Phone: [65] 6344 7322, 6344 8477  
SING LIAN BUILDING      Fax: [65] 6344 9123  
S 419841  
SINGAPORE